

Slitted type

New models released



Protection



Oilproof



Weatherproof



LAN Connector

Relay adaptor

Waterproof and dustproof !

For insulating LAN cables or other preassembled connectors

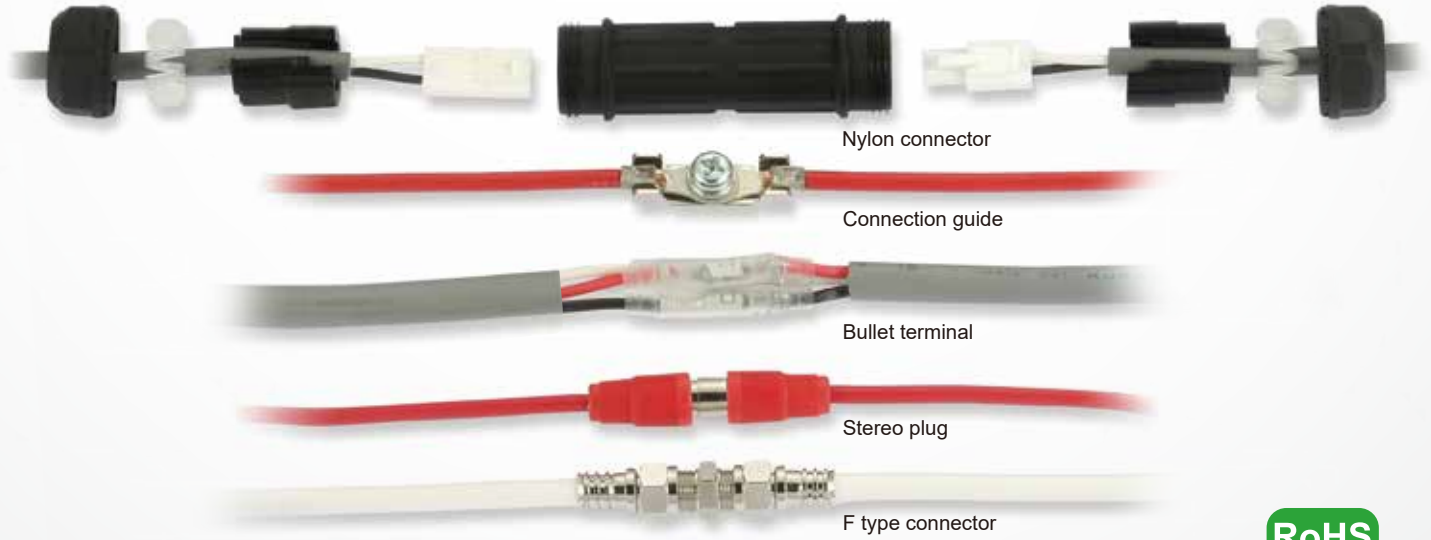

Nylon connector

Connection guide

Bullet terminal

Stereo plug

F type connector



■ Model/Specification ■ Oilproof ■ Rubber bushing: Black ■ Weatherproof ■ Rubber bushing: Blue

Model	Rated Voltage	Applicable cable dia (mm)		Working temp.	Inner space (mm)	Weight	Q'ty per package	Option
		Left	Right					
OA-QW09SRSN	AC/DC 600V	φ 4 to 9	φ 4 to 9	-25 to +80°C	φ 14.6 × 50	25g	10 pcs	Fitting bracket QW-H2 Connection guide QW-J1 QW-J2 QW-J3
OA-QW11SRSN		φ 8.5 to 11.5	φ 8.5 to 11.5			21g		
OA-QW0911SRSN		φ 4 to 9	φ 8.5 to 11.5			23g		
OA-QW09334SRSN		φ 4 to 9	φ 22 to 33(4 holes)			25g		
OA-QW09404SRSN		φ 4 to 9	φ 3 to 4 (4 holes)			25g		
OA-QW11334SRSN		φ 8.5 to 11.5	φ 22 to 33(4 holes)			23g		
OA-QW11404SRSN		φ 8.5 to 11.5	φ 3 to 4 (4 holes)			23g		
OA-QW22-0801SRSN NEW		φ 5 to 8	φ 5 to 8			55g		

※1 Please refer to the "Inner space" in "Dimensions".