

Specification Change Notice for Dust collector “DUSTCUBE” ODU-1000DSA/080HP/1200HP-AT3

Dear Customer

We would like to inform you of an upcoming change of specifications to the above products aiming at parts consolidation of these models.
We look forward to your understanding and continued business in the future.

1. Affected product: 3 models of DUSTCUBE

For clean room High pressure type	ODU-080HP-AT3
	ODU-1200HP-AT3
For clean room Laser marker use	ODU-1000DSA-AT3

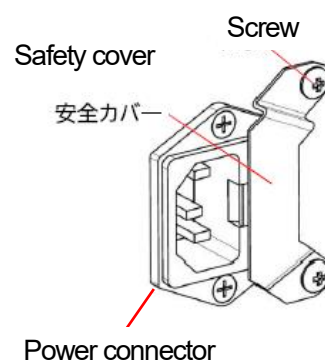

2. Description of change

- A safety cover is added on the power connector (See the illustration above).
Fuse replacement procedure is changed by this alteration.

3. Schedule for change

Starting from production in June 2024 as soon as present stock has run out.

4. Others

There is no change in model and price of DUSTCUBE.

The timing of switchover from the existing model varies by stock condition of each model.

For further details, please contact us at info-cs@ohm.co.jp.

OHM Electric Co., Ltd.

Tomoyuki Sumimura, General Manager
General Manger, Cooling/Environmental Equip. Div.